

NOTES: UNLESS OTHERWISE SPECIFIED

1. ALL DIMENSIONS ARE IN INCHES.
2. CATCH BASIN BODY MATERIAL: 14GA STAINLESS STEEL T304/T316
3. SPECIFYING ENGINEER IS RESPONSIBLE FOR CONCRETE ENGAGEMENT AND REINFORCING BASED UPON APPLICATION AND LOCAL CODES.
4. REFER TO <https://info.slotdrainsystems.com/installresources> FOR INSTALLATION INSTRUCTIONS.

REINFORCED CEMENT CONCRETE SLAB
(±FFL) PER ENGINEER DETAILS

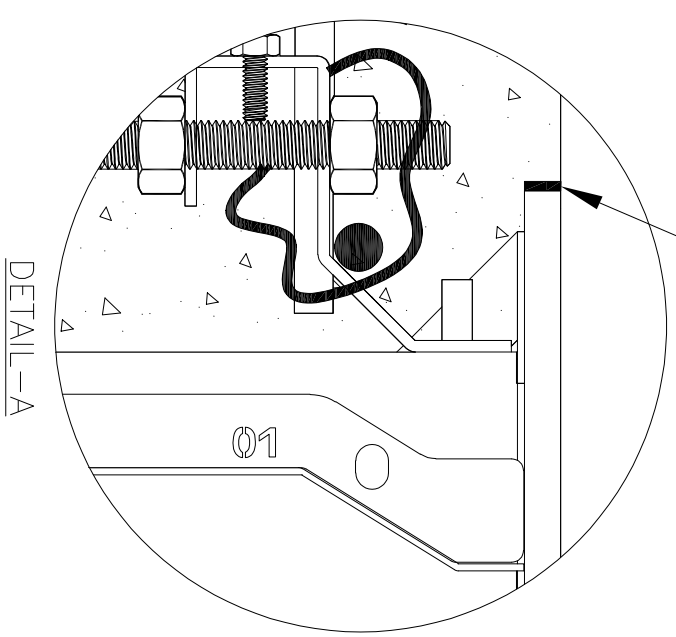
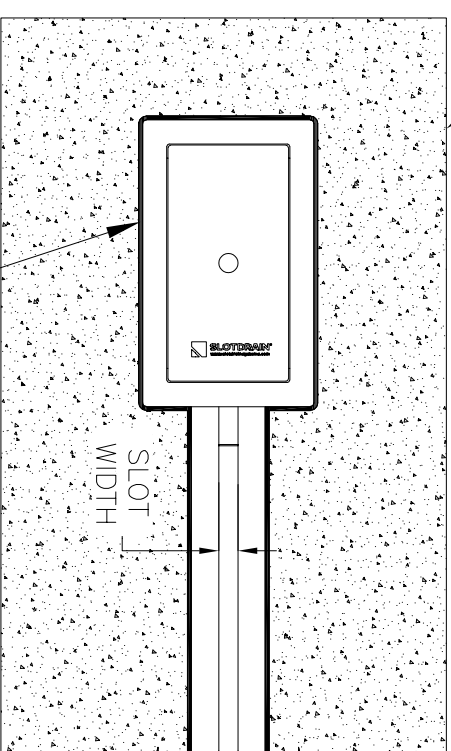
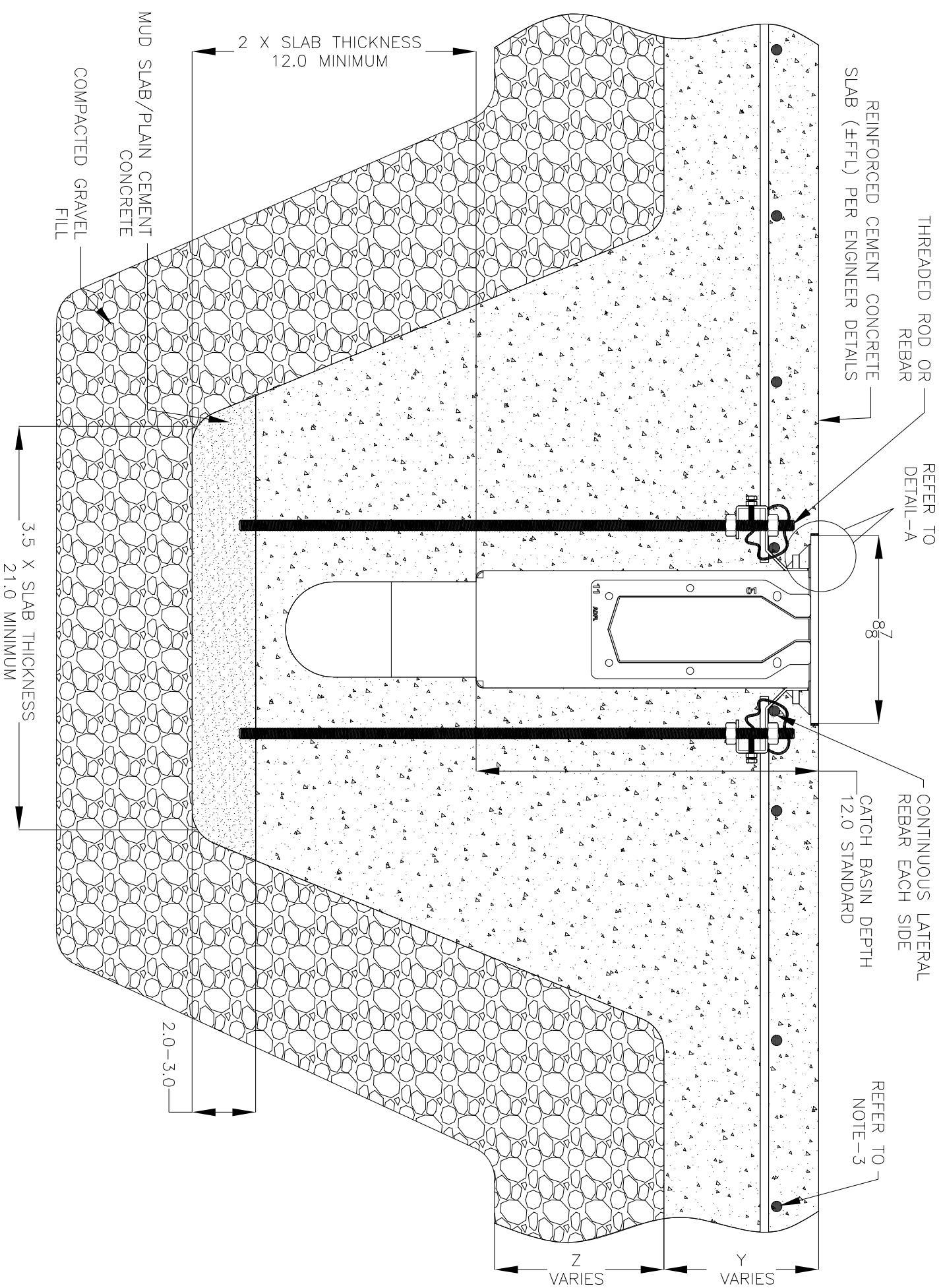

SEALANT BETWEEN ±FFL
AND CATCH BASIN TOP

REVISIONS			
REV	DESCRIPTION	DATE	BY
0	INITIAL RELEASE - R0	11/20/2019	DK
1	UPDATED DRAWING LAYOUT & REBAR DETAILS	7/14/2021	DK
2	UPDATED WITH GLOBAL DRAIN TEMPLATE	3/19/2024	DK

6X12X12 CATCH BASIN INSTALLATION DETAILS



DRAWING TITLE
CONCRETE FLOOR-NEW CONSTRUCTION INSTALLATION

DRAIN SERIES
6X12X12 CATCH BASIN

DWG NO.
IN-6X12X12FGPII-001-R2

ALL DRAWINGS ARE THE EXCLUSIVE PROPERTY OF SLOT DRAIN SYSTEMS. ANY REPRODUCTION IN PART OR IN WHOLE IS PROHIBITED WITHOUT PROPER CONSENT.

SIZE B SCALE NTS SHEET 1 OF 1

REV. 2